

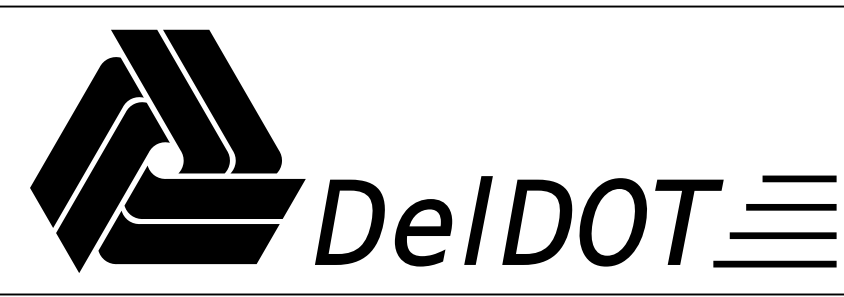

NOTES:

1. ALL WIRES SHALL BE LASHED WITH FIVE (5) WRAP (12" O.C.) ELECTRICAL TAPE ACROSS SPAN WIRE.
2. POLES SHALL BE RAKED AS SPECIFIED BY THE ENGINEER.
3. POLE PLACEMENT SHALL BE OUTSIDE OF THE CLEAR ZONE BASED ON THE GUIDELINES OF THE MOST RECENT AASHTO ROADSIDE DESIGN GUIDE.
4. SPAN WIRE SHALL BE PLACED UNDER ALL RISERS.
5. SPAN WIRE SHALL BE 7/16" SEVEN (7)-WIRE GAL. STEEL STRAND. (STRENGTH SHALL BE SIEMENS-MARTIN 6.950 LBS.)
6. TETHER WIRE SHALL BE 1/4" SEVEN (7)-WIRE GAL. STEEL STRAND. (STRENGTH SHALL BE SIEMENS-MARTIN 3.150 LBS.)
7. TWO (2) THREE-BOLT CLAMPS SHALL BE USED FOR EACH END OF THE SPANS.
8. SPAN INSULATOR SHALL BE INSTALLED ON THE SPAN(S) CLOSEST TO THE CABINET, 15-20 FEET FROM THE POLE (OR AS DIRECTED BY THE ENGINEER).
9. REFER TO TRAFFIC DESIGN MANUAL FOR MORE INFORMATION PERTAINING TO VERTICAL CLEARANCE FOR SIGNAL HEADS.

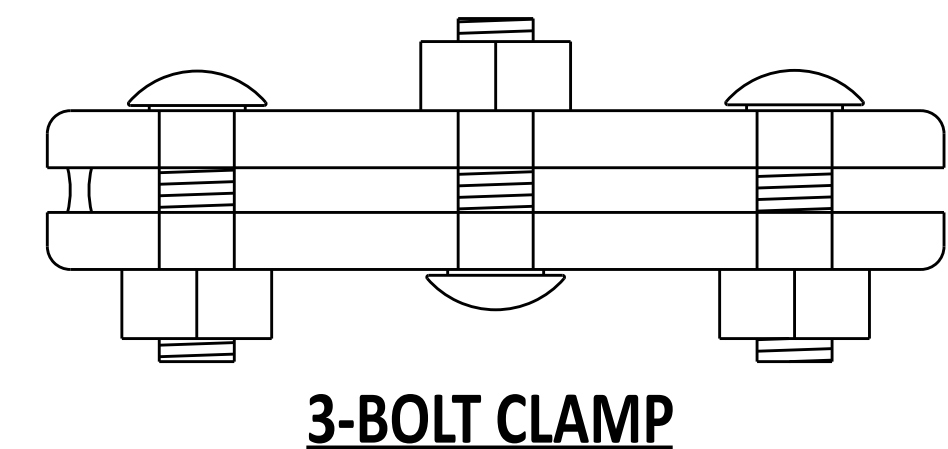

 Andrew Shott
 ENGINEERING SUPPORT
 12/22/2023
 DATE
RECOMMENDED

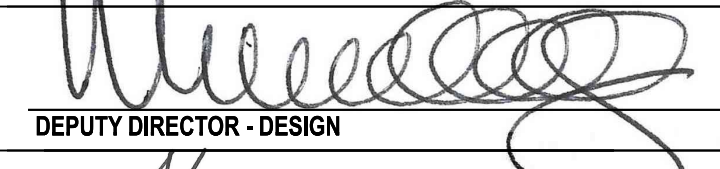
SPAN WIRE ASSEMBLY			
STANDARD NO.	T-12 (2024)	SHT. 3	OF 3

REVIEWED

 DEPUTY DIRECTOR - DESIGN
 22 December 2023
 DATE
APPROVED

 CHIEF ENGINEER
 01/11/2024
 DATE