

SECTION C-C

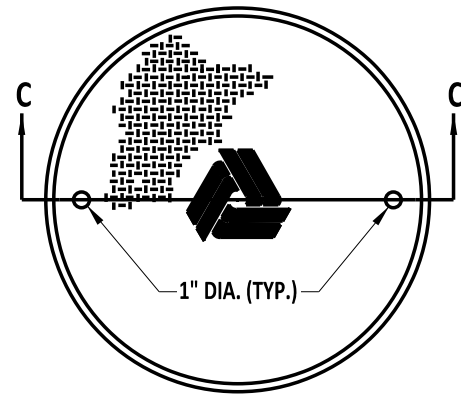

COVER

NOTES:

- 1). DETAILS SHOWN ARE FOR CAST-IN-PLACE GRADE RINGS. BUILD GRADE RINGS TO GRADE AS SPECIFIED ON PLAN SHEETS OR AS DIRECTED BY ENGINEER.
- 2). IF GRADE RINGS ARE PRECAST, DESIGN SPECIFICATIONS SHALL CONFORM TO AASHTO M-199, LATEST REVISIONS.
- 3). COLLAR DETAILS SHOWN ARE FOR CAST-IN-PLACE CONSTRUCTION AROUND MANHOLE ADJUSTMENTS AND REPAIRS. COLLAR DETAIL IS NOT INTENDED FOR NEW CONSTRUCTION
- 4). PROVIDE MINIMUM COVER OF 1 1/2".

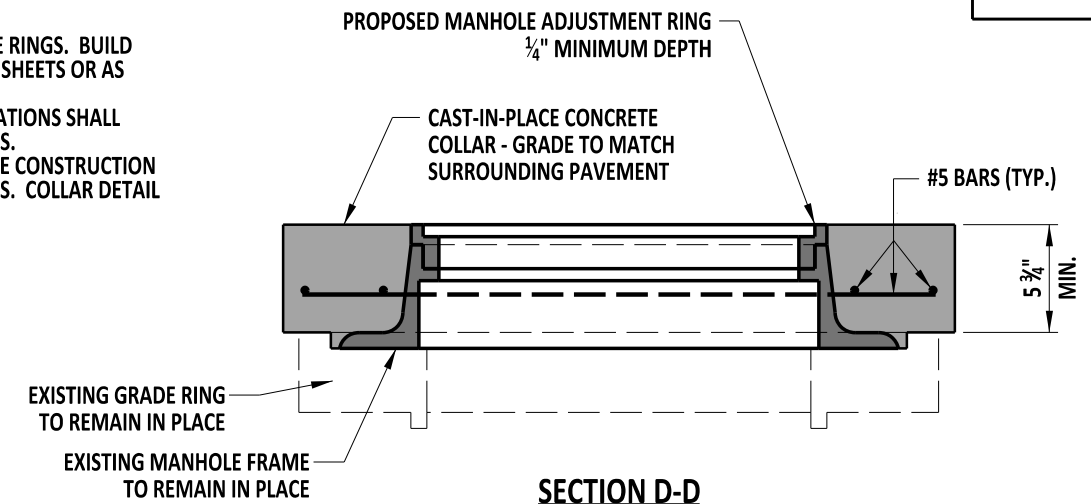

SECTION D-D

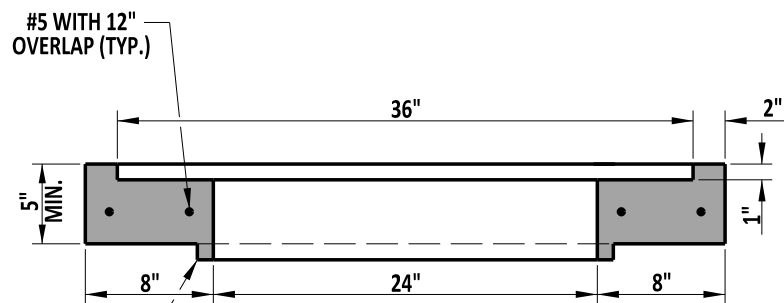

SECTION A-A

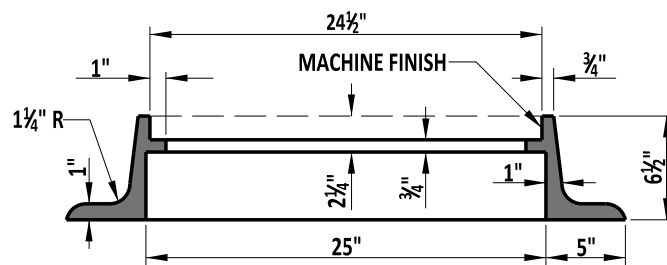

SECTION B-B

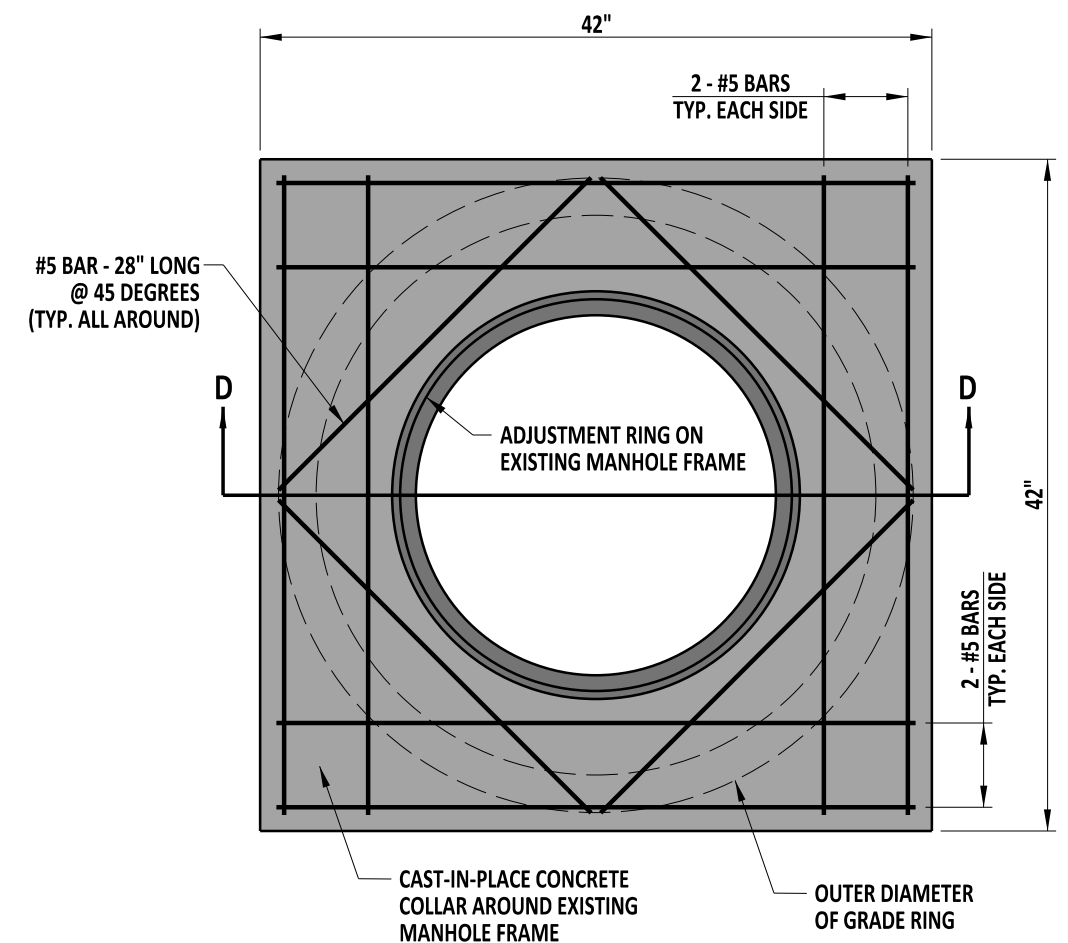

NOTES:

- 1). USE TOP UNIT WHERE BITUMINOUS PAVEMENT IS NOT AVAILABLE.
- 2). WHERE COLLAR EXTENDS BEYOND GRADE RING, PREPARE ADEQUATE SUB-BASE.

TOP UNIT

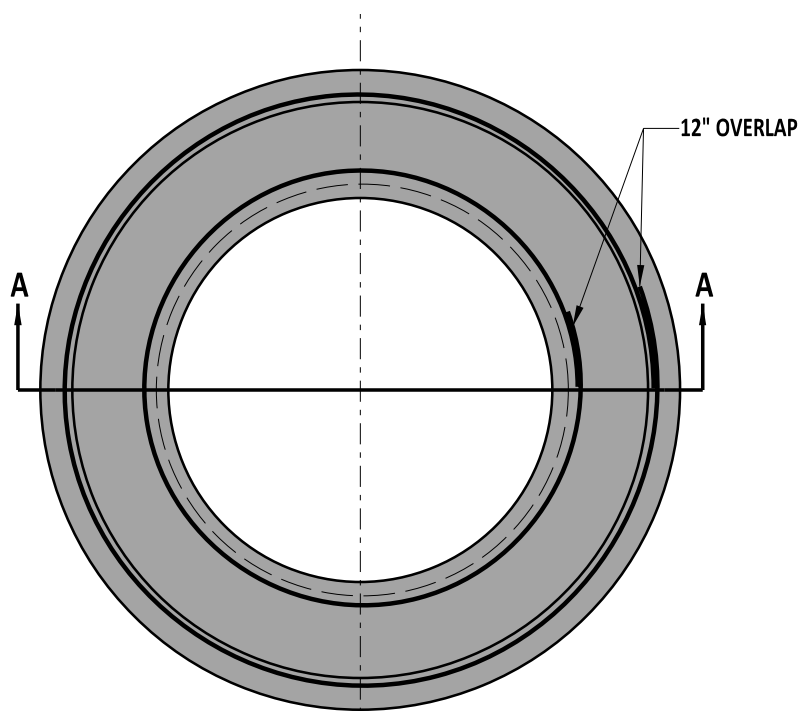

GRADE RING

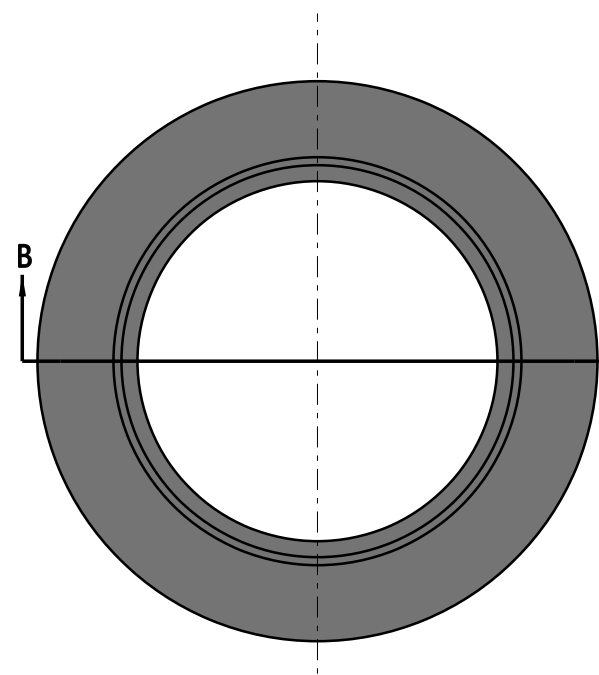

FRAME



ENGINEERING SUPPORT *Paul John* 09/01/2020
RECOMMENDED DATE

MANHOLE GRADE RING, TOP UNIT, FRAME AND COVER
STANDARD NO. D-6 (2020) SHT. 3 OF 5

REVIEWED *Mike Lee* 09/01/2020
DEPUTY DIRECTOR - DESIGN DATE
APPROVED *Shery* 09/01/2020
CHIEF ENGINEER DATE