

ALUMINUM PANEL - NOTCHED CORNERS (SEE NOTE 1)

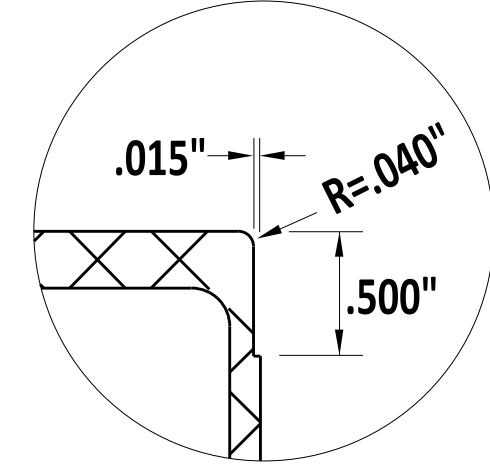

DETAIL B

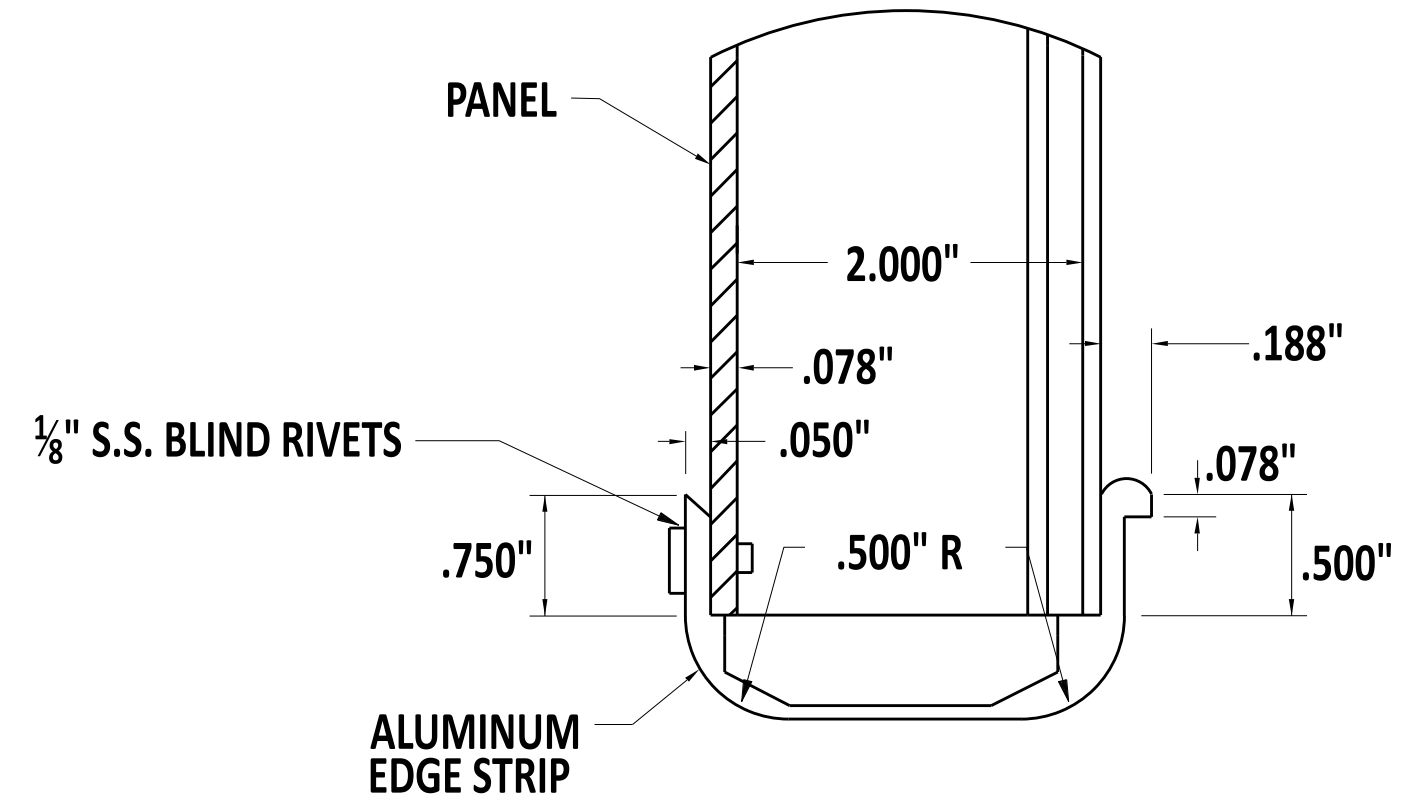

DETAIL OF EDGE STRIP

NOTE:
EDGE STRIP SHALL BE PLACED ON BOTH SIDES OF ALL EXTRUDED PANEL SIGNS.

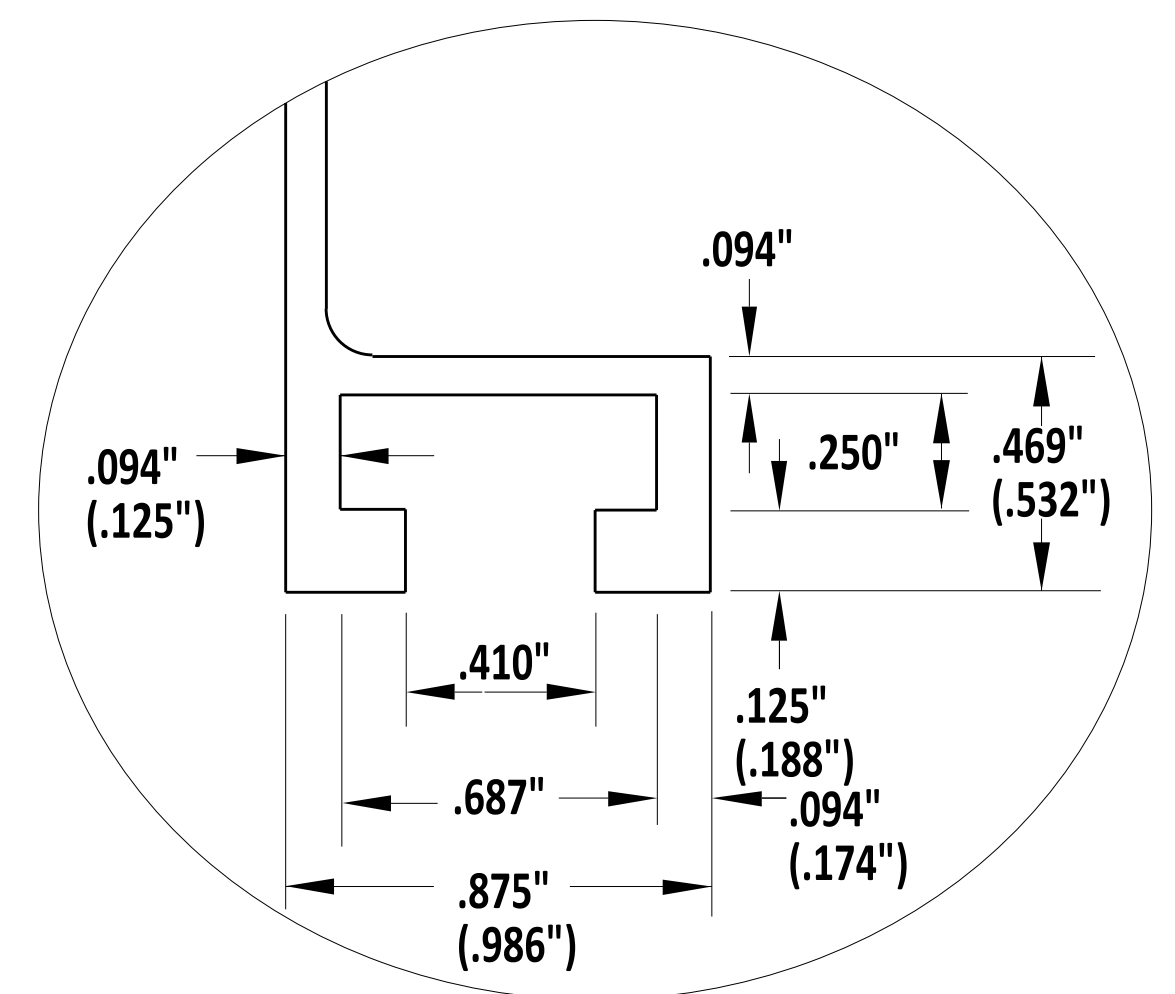

DETAIL A

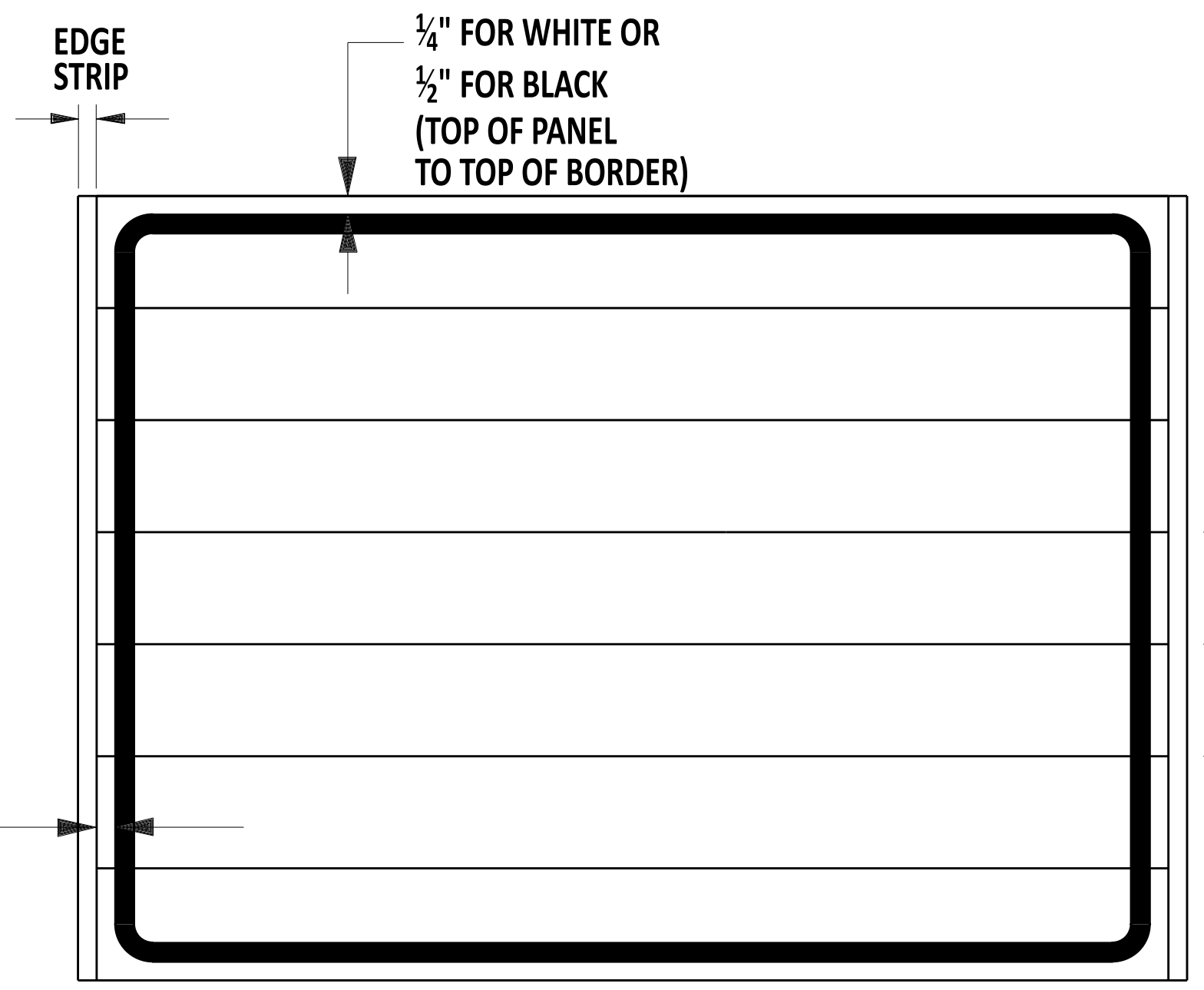

BORDER DETAIL

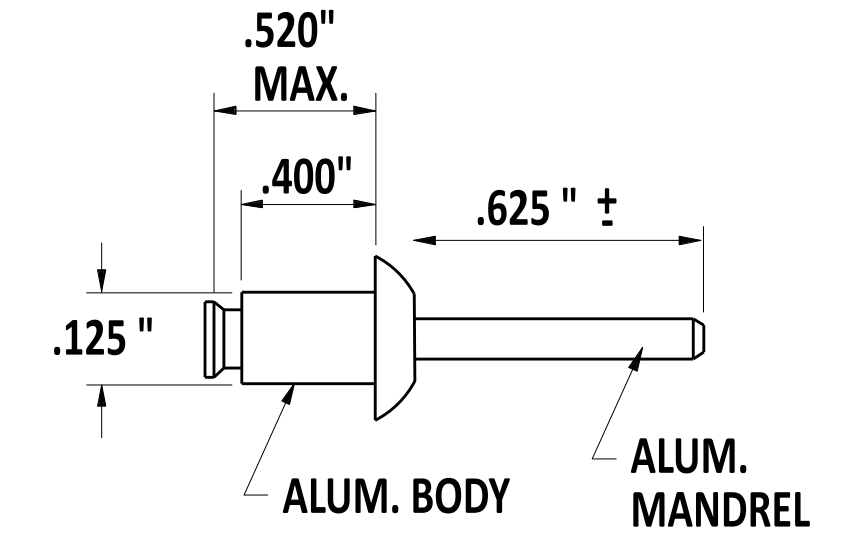
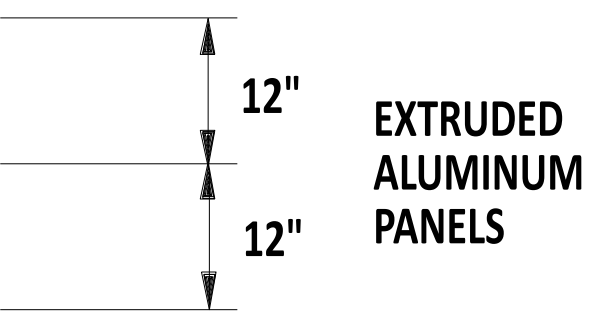

DETAIL OF A BLIND RIVET FOR CUTOUT LETTER (TYP.)

- NOTES:**
1. ALUMINUM PANELS SHALL HAVE NOTCHED CORNERS AS SHOWN. NO OTHER TYPE CORNERS ARE ACCEPTABLE.
 2. ALTERNATE DIMENSIONS INDICATED IN PARENTHESES ARE ACCEPTABLE.
 3. THE REFLECTIVE SHEETING APPLIED TO EXTRUDED PANELS SHALL EXTEND APPROX. 3/8" OVER EACH SIDE IN THE NARROW DIRECTION AND SHALL BE ADHERED TO THE PANEL.



Andrew Shott
ENGINEERING SUPPORT 12/22/2023 DATE
RECOMMENDED

EXTRUDED ALUMINUM DETAIL
STANDARD NO. T-26 (2024) SHT. 1 OF 2

REVIEWED *[Signature]* 22 December 2023 DATE
DEPUTY DIRECTOR - DESIGN
APPROVED *[Signature]* 01/11/2024 DATE
CHIEF ENGINEER