

**INTEGRAL PCC CURB AND GUTTER**  
TYPE 1-8

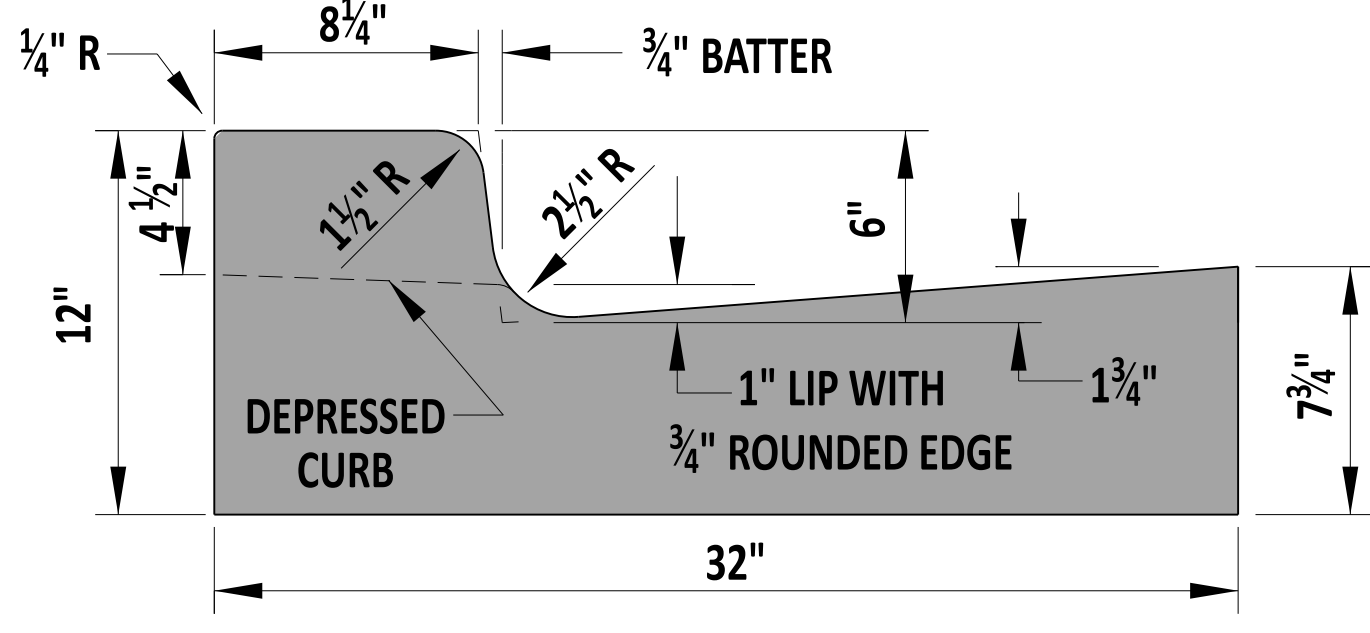

**INTEGRAL PCC CURB AND GUTTER**  
TYPE 1-6

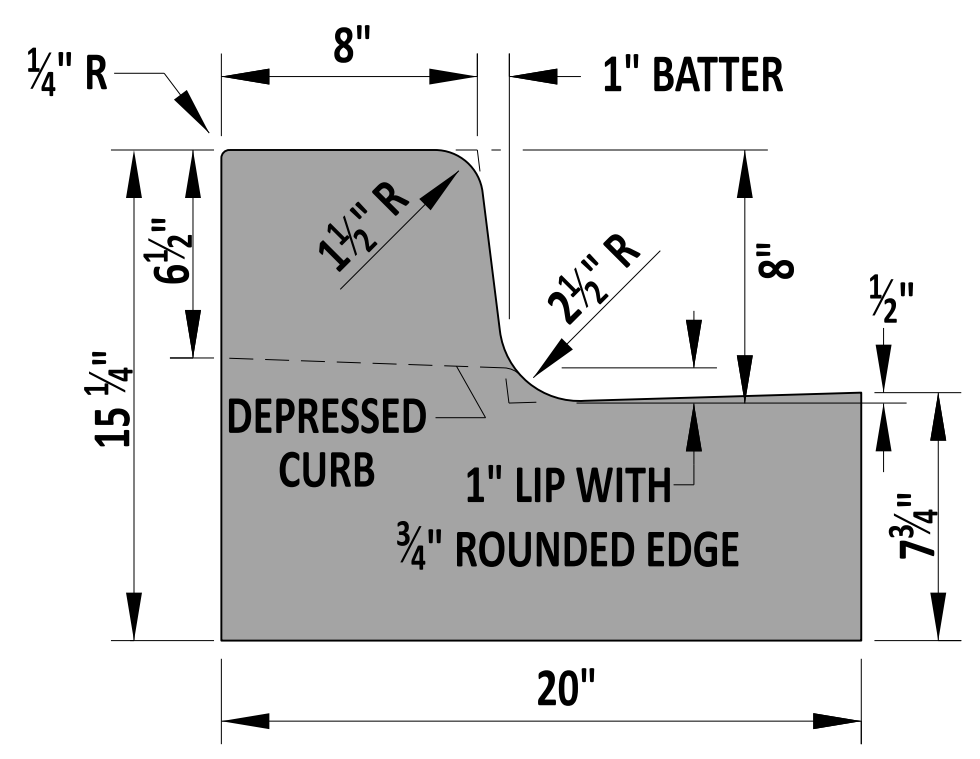

**INTEGRAL PCC CURB AND GUTTER**  
TYPE 3-8

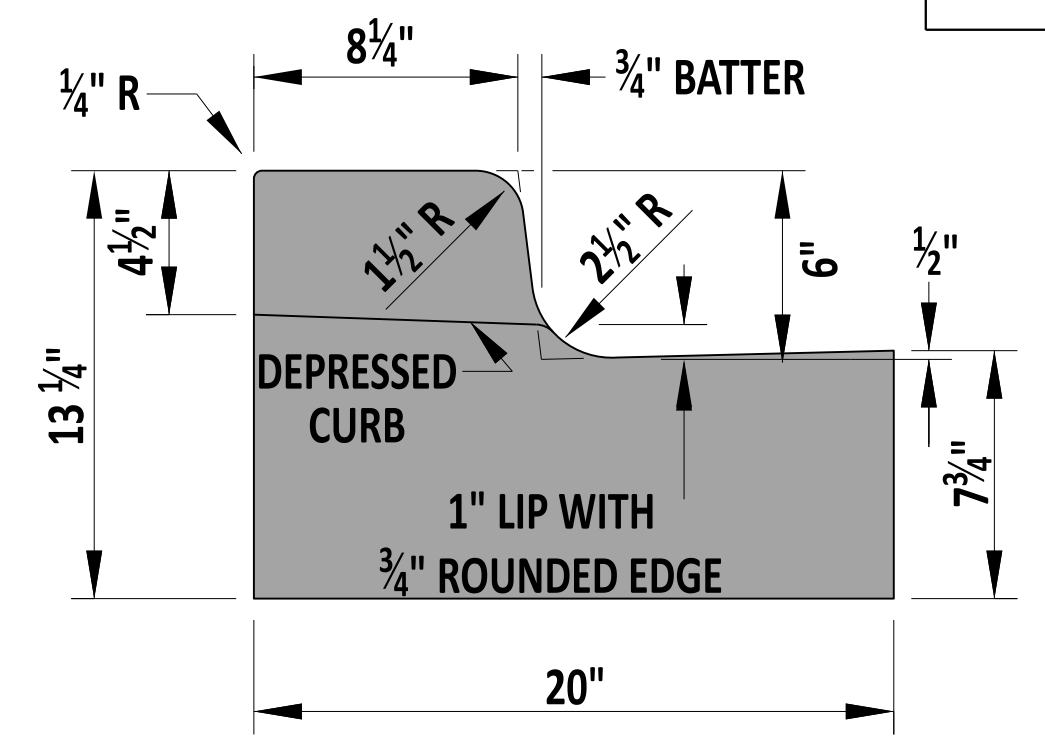

**INTEGRAL PCC CURB AND GUTTER**  
TYPE 3-6

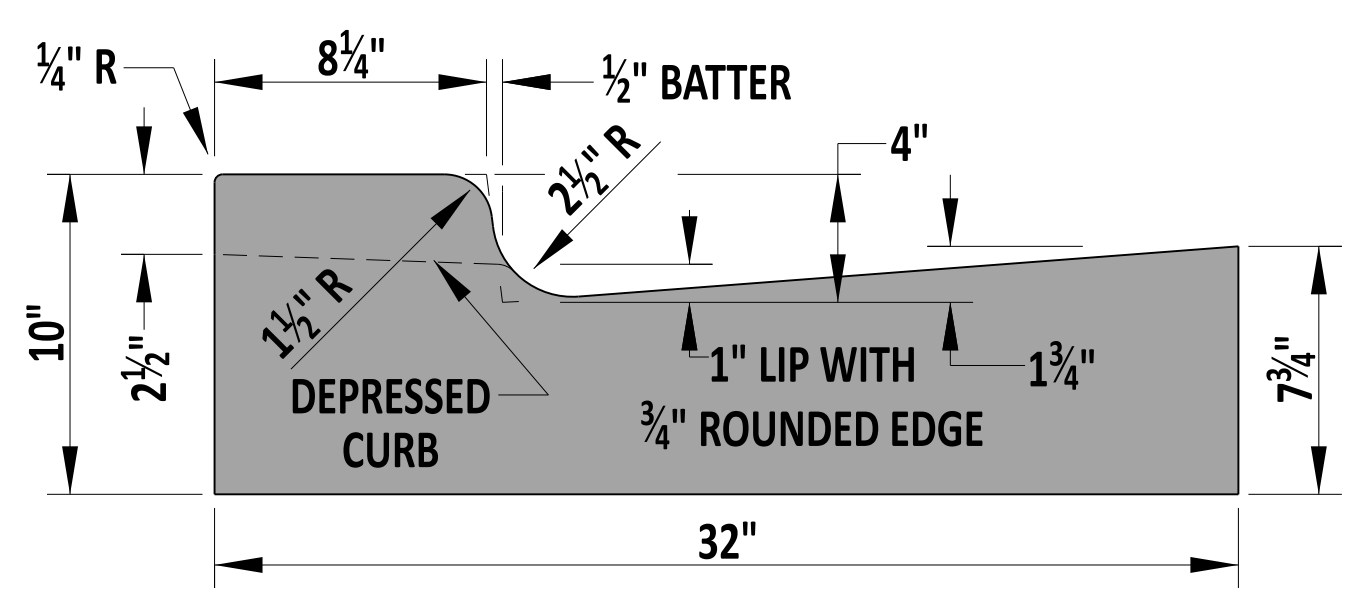

**INTEGRAL PCC CURB AND GUTTER**  
TYPE 1-4

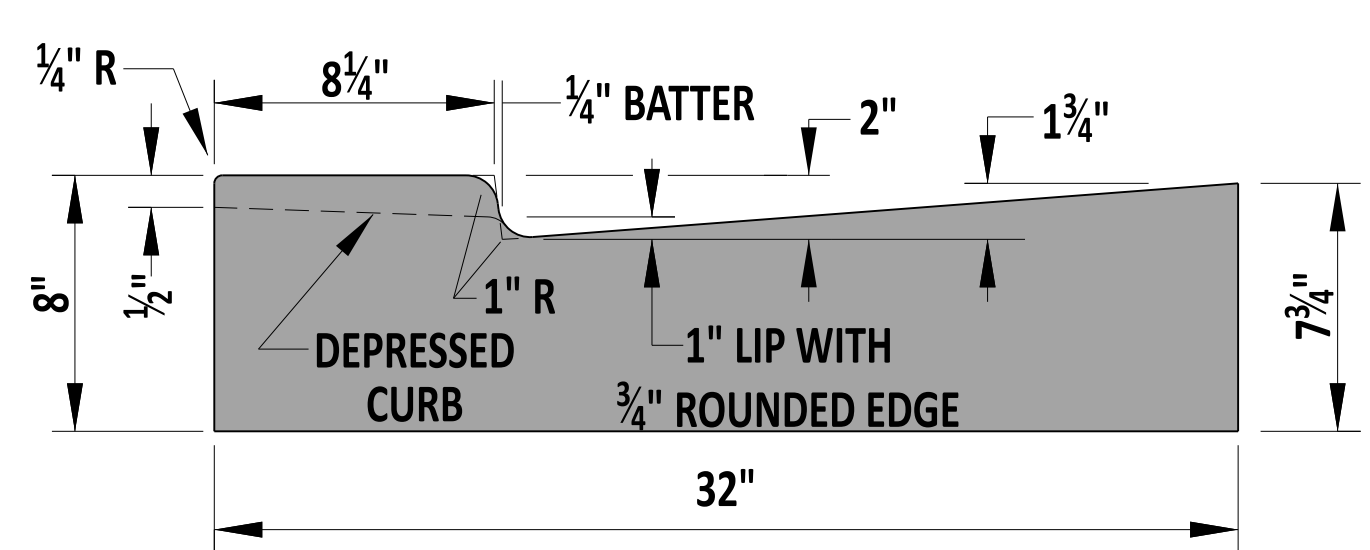

**INTEGRAL PCC CURB AND GUTTER**  
TYPE 1-2

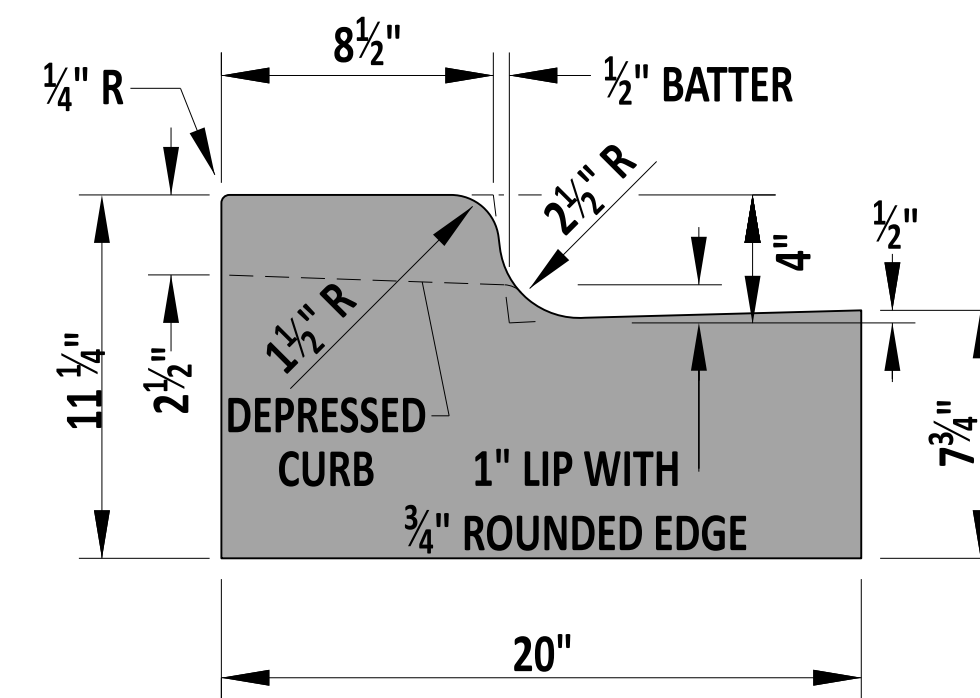

**INTEGRAL PCC CURB AND GUTTER**  
TYPE 3-4

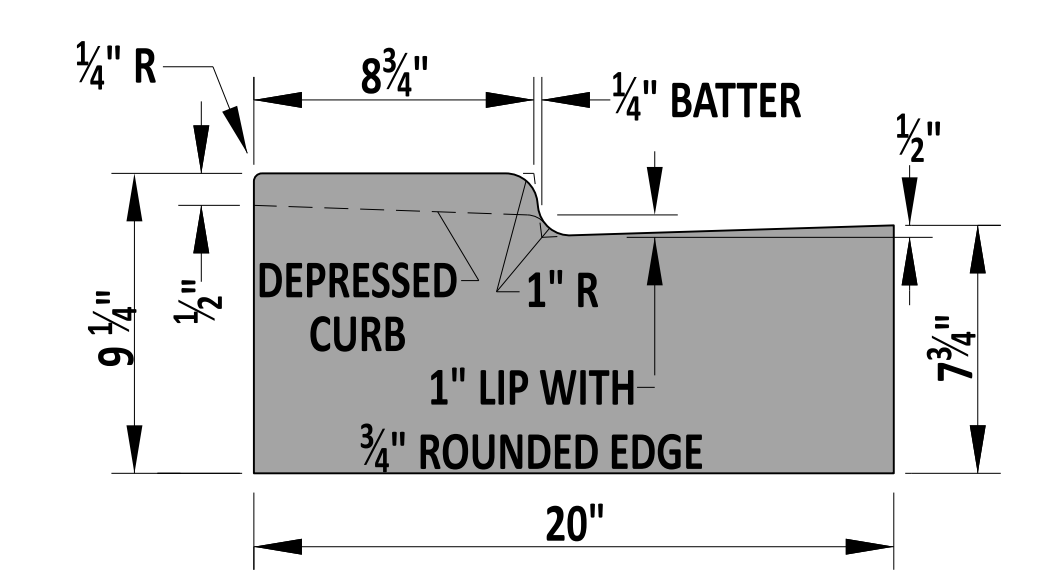

**INTEGRAL PCC CURB AND GUTTER**  
TYPE 3-2

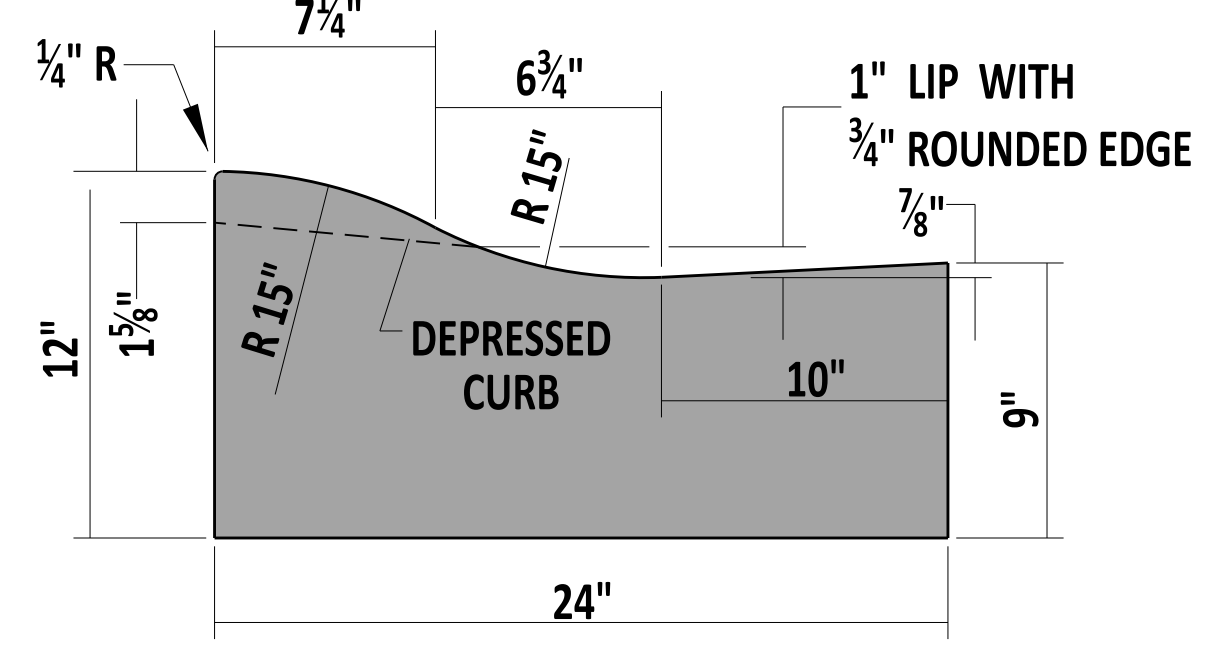

**INTEGRAL PCC CURB AND GUTTER**  
TYPE 2

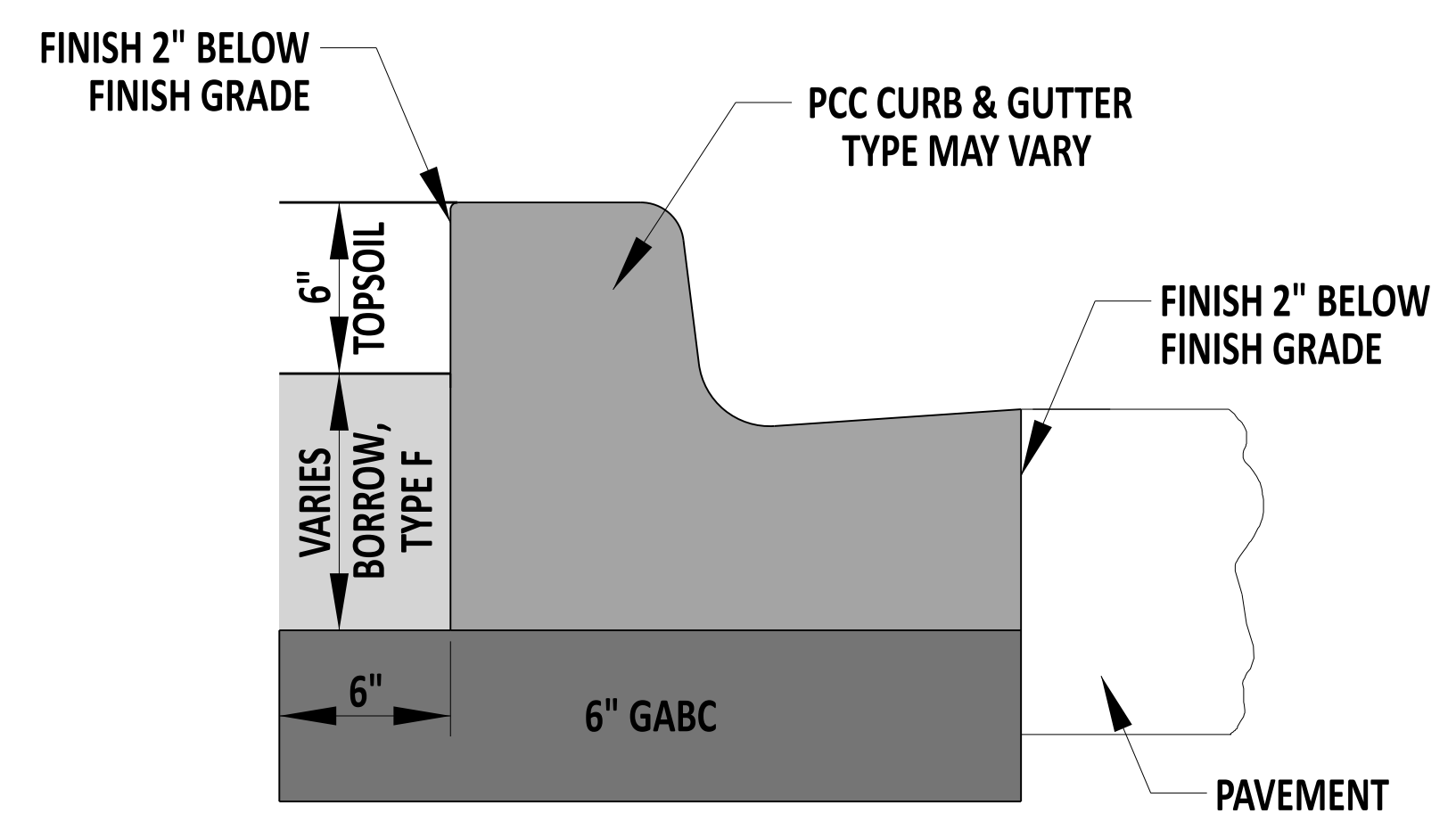

**TYPICAL PCC CURB AND GUTTER SECTION**

- NOTES:**
- 1). CONSTRUCT IN ACCORDANCE WITH SECTION 701.
  - 2). WHEN PCC CURB OR INTEGRAL PCC CURB AND GUTTER IS PLACED ADJACENT TO PORTLAND CEMENT CONCRETE PAVEMENT, CONSTRUCT THE JOINT AS PER THE LONGITUDINAL JOINT SEALANT DETAIL ON DETAIL P-2, SHEET 3 OF 5. USE APPROVED JOINT FILLER TO SEAL. WORK TO BE PAID UNDER RESPECTIVE CURB AND GUTTER ITEM.
  - 3). THE DEPRESSED CURB DIMENSIONS (INCLUDING 1" LIP) ON THIS SHEET ARE FOR USE AT ENTRANCES ONLY. FOR CURB DIMENSIONS AT PEDESTRIAN CONNECTION, SEE DETAIL C-1, SHEET 3.
  - 4). DIMENSIONS FOR CURB AND GUTTER BATTER AND PAN ARE MEASURED TO THE HINGE POINT.
  - 5). DEPRESS CURB FLUSH WITH PAVEMENT OR ADJACENT AREA AT LEADING EDGE OF TRIANGULAR ISLANDS, TAPERING BACK TO FULL HEIGHT AT A SLOPE OF 4:1. SEE DETAIL C-1, SHEET 1 OF 4 FOR TYPICAL SECTION OF TAPER AT NOSE OF MEDIAN ISLANDS.
  - 6). DEPRESS END OF CURB RUNS NOT PART OF AN ISLAND OR MEDIAN FLUSH WITH PAVEMENT OR ADJACENT AREA AT A SLOPE OF 12:1.



*Andrew Short*  
ENGINEERING SUPPORT  
RECOMMENDED  
DATE 12/22/2023

**INTEGRAL PCC CURB & GUTTER**  
STANDARD NO. C-1 (2024)  
SHT. 2 OF 4

REVIEWED  
APPROVED  
DEPUTY DIRECTOR - DESIGN  
CHIEF ENGINEER  
22 December 2023  
DATE  
01/11/2024  
DATE